

# INDUSTRIAL VIBRATING FEEDERS

COAL - AGGREGATES  
ORES - RECYCLING

- ▶ A standard range and bespoke to suit customer requirements
- ▶ Size and duty as required
- ▶ Choice of protective and noise reducing liners
- ▶ Designed & built for continuous operation
- ▶ Tens of millions of tons per annum on large machines
- ▶ Ultra durable to withstand the most demanding environments
- ▶ Ultra reliable, providing decades of operational peace of mind
- ▶ Excellent payback on investment



DESIGNED AND BUILT IN THE UNITED KINGDOM 

# INDUSTRIAL VIBRATING FEEDERS

We build vibrating feeders to suit virtually any appropriate industrial application. Our machines are always designed and manufactured to exceed the demands which will be put on them either by the nature of the feedstock, the operation, the environment in which the machine will operate, or any of these factors combined. We only build machines which last.

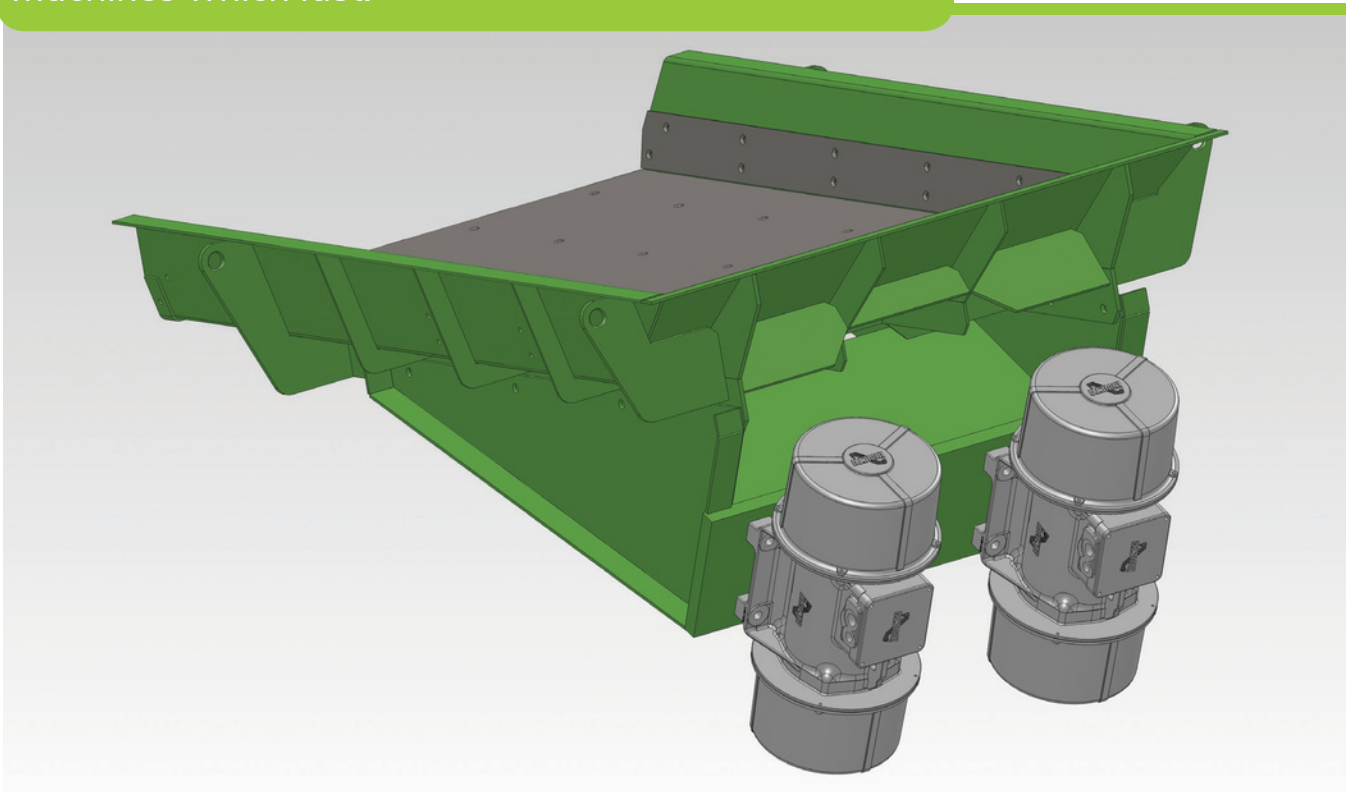

## GET YOUR VIBRATING FEEDER DESIGNED BY THE EXPERTS

Our application engineers will be pleased to provide you with a specification for the best vibrating feeder to meet your requirements. Simply provide us with the following basic information:-

- ▶ Type of material
- ▶ Size analysis of feed material
- ▶ Bulk density
- ▶ Feed rate (tph)
- ▶ Moisture content



Don Valley Engineering Co. Ltd.  
Sandall Stones Road,  
Doncaster, DN3 1QR  
United Kingdom

## WORLD CLASS PROCESS MACHINERY

Tel: +44 (0) 1302 881188  
Fax: +44 (0) 1302 881000  
Email: [info@donvalleyeng.com](mailto:info@donvalleyeng.com)  
Web: [www.donvalleyeng.com](http://www.donvalleyeng.com)

